

inohom
Smart Life Solutions

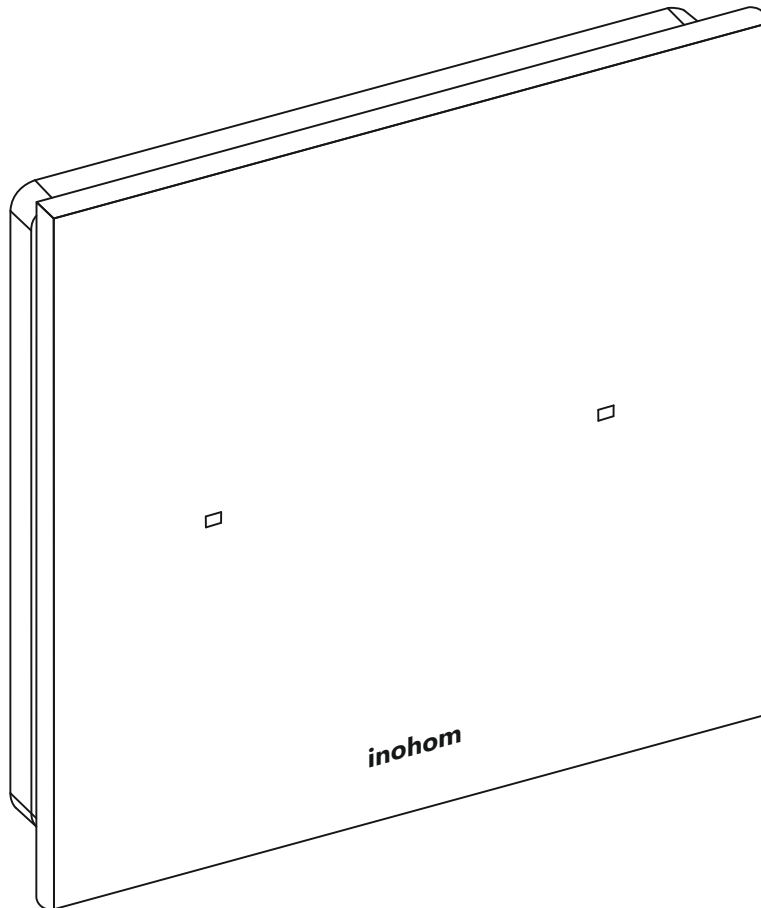

Smart Touch Switch 2

(STS1720)

USER MANUAL

Content

1: Important Safety Information	3
2: Description and Properties	4
3: Technical Properties	4
3.1: Technical Details	4
3.2: Technical Drawing	5
4: Installation	5
4.1: Before Installation	5
4.2: Mechanical and Electrical Assembly	6
4.2.1: Return to Factory Settings	6
4.2.2: Electrical Assembly	6
4.2.3: Mechanical Assembly	7
5: Communication Properties	8
6: Button Functions	9
7: Commissioning	10
8: Regulations	11

1: Important Safety Information

Please read this manual before using the device!



Not following the recommendations in this manual might lead to danger. The manufacturer GST ELEKTRONİK LTD ŞTİ cannot be hold responsible for any loss or damages arising from not following the instructions in this user manual. Device is no longer under warrant after faults arising in these cases.

ELECTRIC SHOCK DANGER!



The device is designed to control other electronic devices and operates in houses. Incorrect connection or usage might cause fire or electric shocks.



There might be voltage on the connection tips even if the device is turned off. The fuse or power source must always be disabled if the connections will be changed.



Do not operate the device with wet or moist hands to avoid electric shock risk.

Do not open the product!



Do not make any changes on this device that are not specified in the user manual.

Other devices



The manufacturer GST ELEKTRONİK LTD. ŞTİ. cannot be held responsible for any damages or out-of-warranty if any unsuitable connections other than the connections expressed in the connection manual are made with other devices.

This product is designed only for indoors use in a dry environment.



Do not use the product in wet or damp environment such as bathtub, sink, bath and pool.

Device Cleaning



Do not clean the product with solvent (thinner, gasoline, acid etc.) or abrasive cleaning products. Avoid cleaning with vapour cleaning tools.

Heat Sources and Fire



Do not leave the device directly exposed to sunlight or other heat sources. Do not place the device near open fire or intense heat sources such as electric heater.

2: Description and Properties

Inohom Smart Touch Switch 2 (STS1720) enables illumination, on/off control, automatic curtain-blind control and scenario activation management. The product has 2 programmable touchscreen buttons.

The product has 2 built-in 16A 277V~ Relay output. Usage with or without relay is possible. This product can be mounted to standard switch cases. The product has tempered glass design and touchscreen LED buttons.

There are black and white glass colour options.

3: Technical Properties

3.1: Technical Details

Supply Voltage	12VDC or 100-240VAC
Power Consumption	1.2W (Max)
Outputs	2 Relay (277VAC 16A inrush 100A)
Buttons	Capacitive Touchscreen
Communication	RF 433 Mhz
Operating System	inohom OS
Connections	2.5mm ² screwed electric terminal
Protection Class	IP 20
Operating Temperature	0 - 50°C
Relative Humidity	Max 50°C %65 Ambient Humidity
Height	Max 2000m
Dimensions	90mm x 90mm x 14mm
Installation	Surface Wall Mounting
EMC Standards	EN55032:2015, EN55024:2011, EN62368-1
Design	4mm Tempered Glass Surface

3.2: Technical Drawing

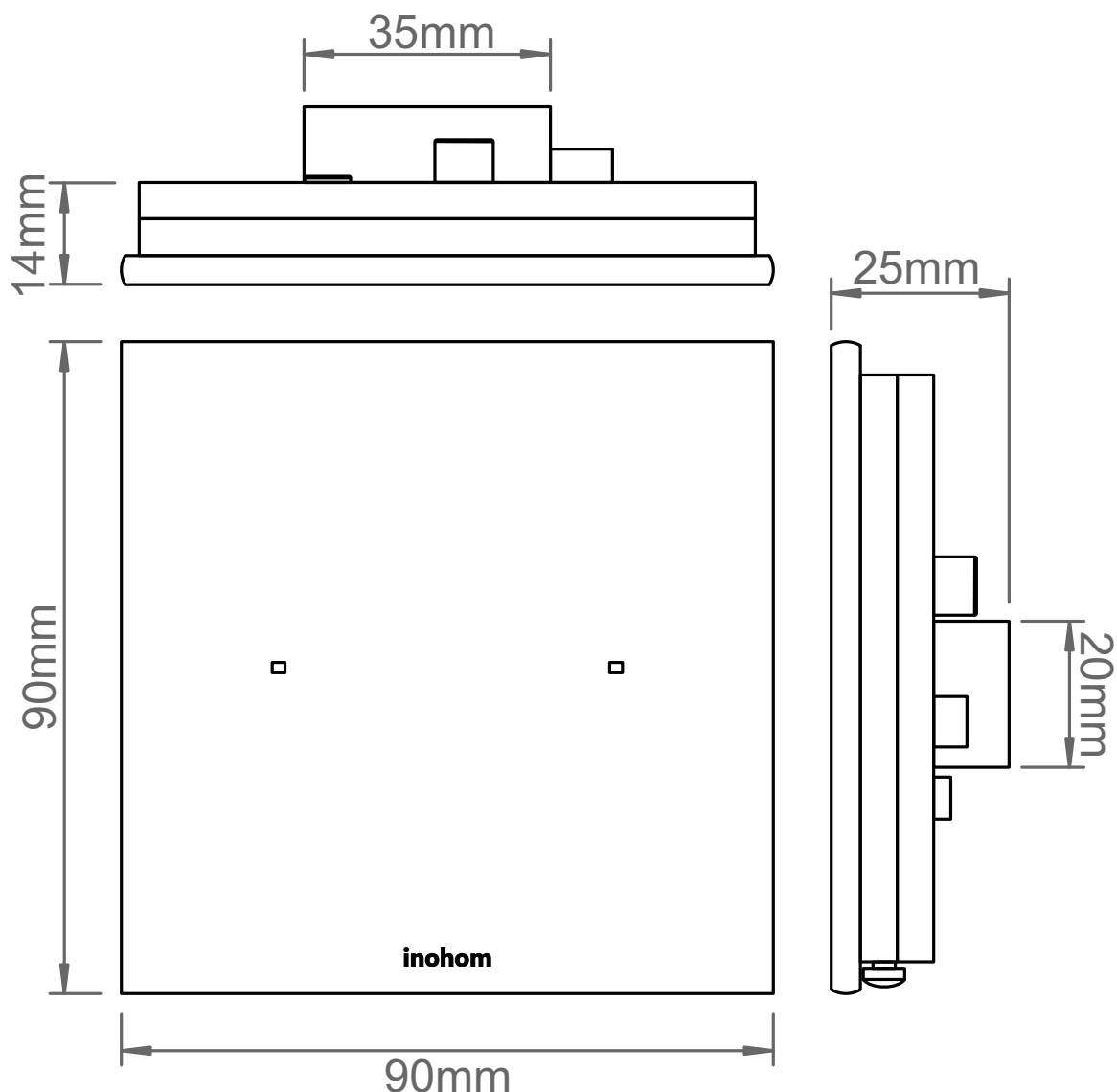

4: Installation

4.1: Before Installation



Unsuitable connections against the manual might cause health, life or material damage risk.

- Do not power on the device before all the connections are completed.
- Check the device user manual to create a secure connection.
- Do not make any connections other than the connections specified in the scheme.
- Do not connect with devices that do not comply with security standards.



Mount the device away from metal surfaces or objects to avoid any negative impact on the wireless communication performance.

4.2: Mechanical and Electrical Assembly

4.2.1: Return to Factory Settings

i Device; When the “R” and “G” contacts are kept in the short circuit position for 10 seconds with a conductive cable, it returns to the factory settings.

4.2.2: Electrical Assembly

i With relay group that can be mounted at the back of the device, you can make various on-off controls over Smart Touch Switch 2. The relays are resistant up to 277VAC 16A inrush 100A and enables long-term use without relay adhesion.

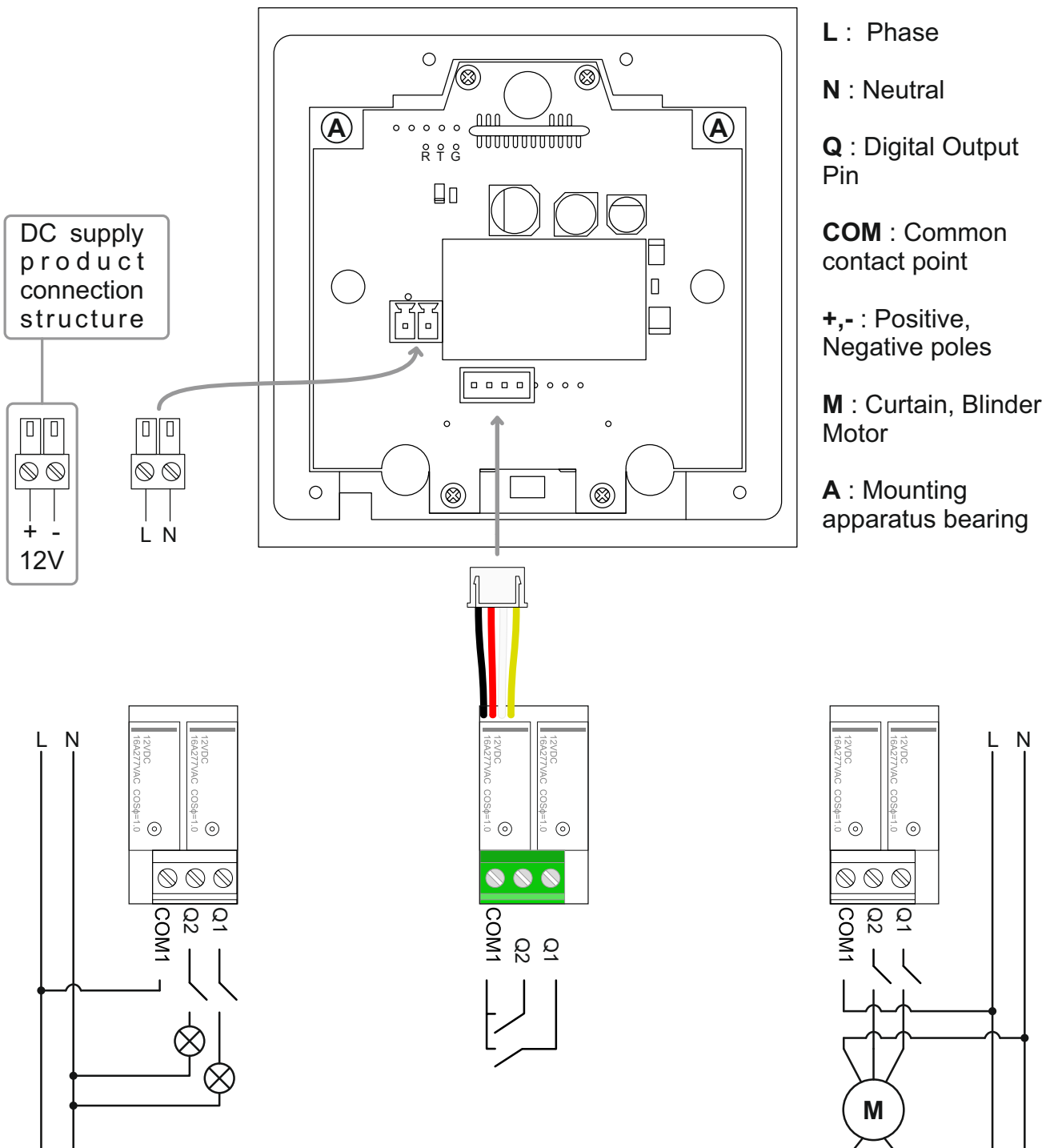

4.2.3: Mechanical Assembly

i The product mounting apparatus is designed with European standard flush mounted box dimensions. The flush mounted box should be placed 120 cm above the ground. Use the mounting apparatus in the box for mounting. Please use the corresponding holes of mounting apparatus to mount switch case. Make sure that the apparatus is perpendicularly mounted to the ground. The holes on the mounting metal sheet allows 20° deviation for fine tuning.



Please avoid overtightening the lower mounting screw.

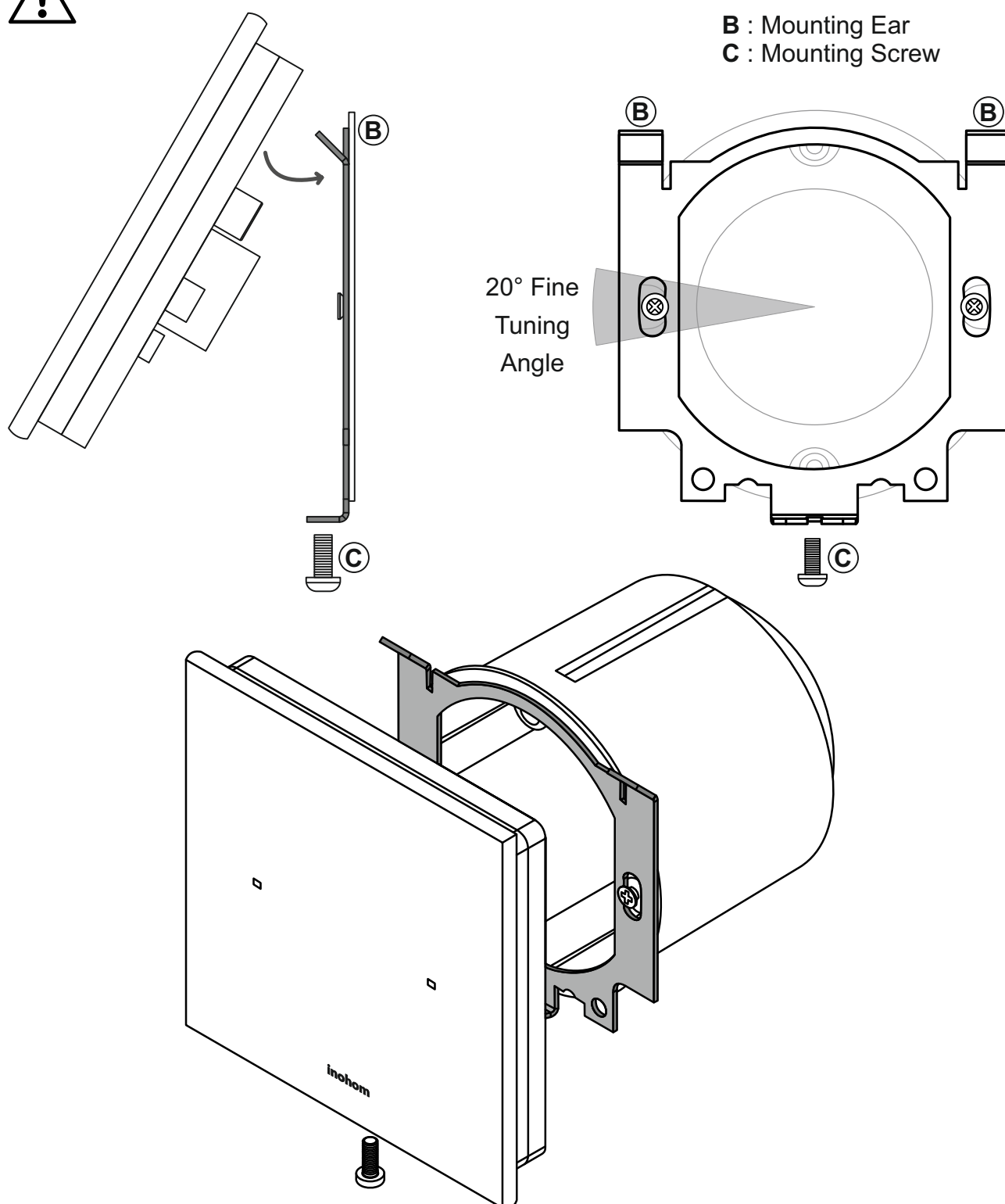

5: Communication Properties

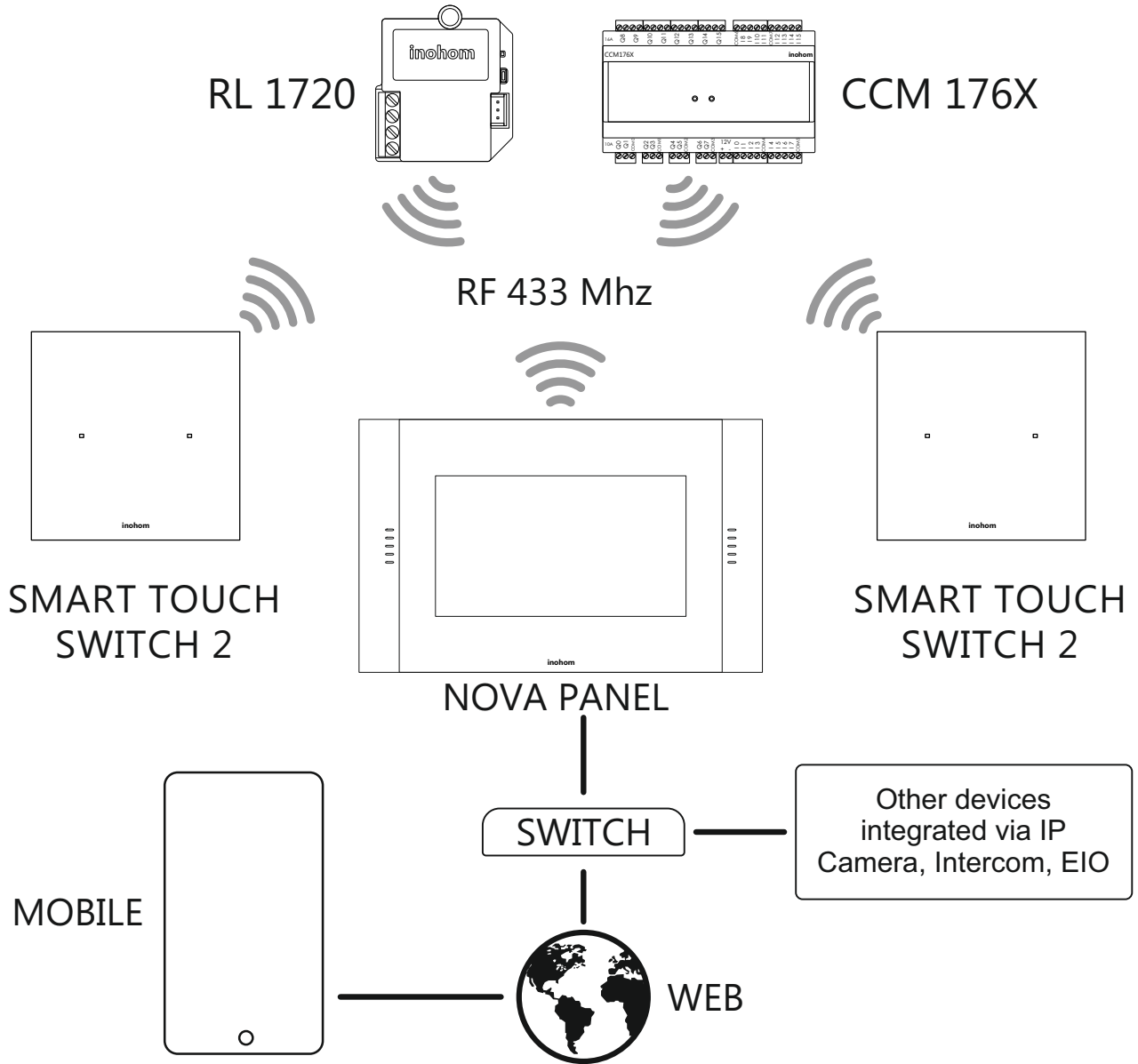

The devices use inohom communication protocol. Smart Touch Switch 2 can wirelessly communicate with other inohom products and can learn and change output and state values of other products.



inohom IP Gateway devices (Nova Panel/Home Manager) enable managing other devices integrated to the automation via the internet by enabling the system to communicate on IP layer.



The product can be optionally used with or without relay.

6: Button Functions

i inohom Smart Touch Switch series switch buttons can be assigned with different tasks. The tasks assigned to the buttons are adjusted by inohom authorized dealer. This operation is completed by trained technical personnel in commissioning program.

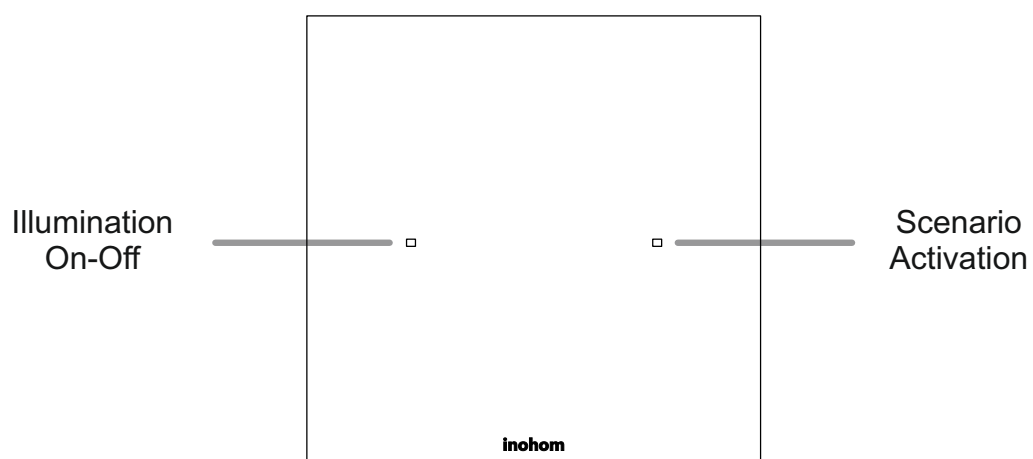
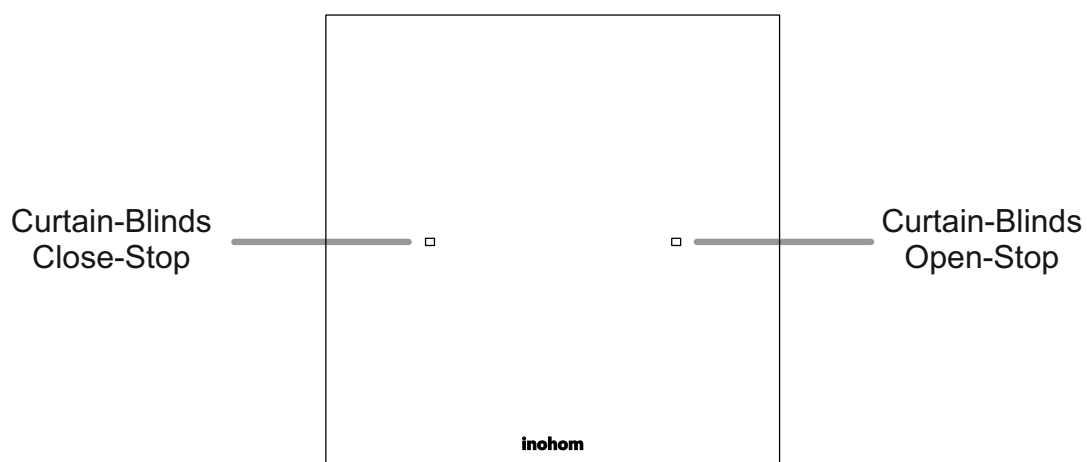
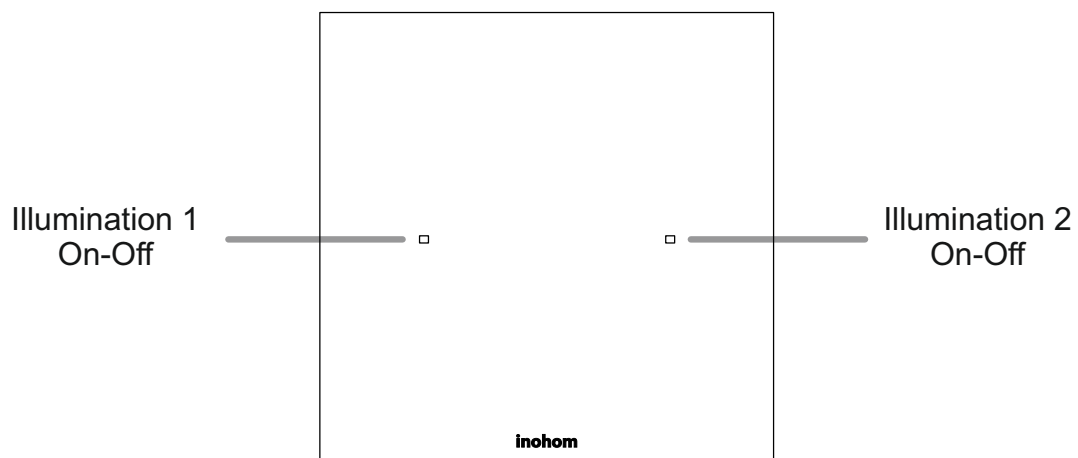

7: Commissioning



 The commissioning of the inohom products after assembly is completed by the authorized inohom dealers and technical staff. Detailed management panel interface ensured communication and other settings between the devices.

At commissioning stage, the “FIND” button on the automation control panel interface is used to identify the related device.

The LEDs on the device will blink with 1 second interval when pressed “FIND” button and press “STOP” button when the device is found.

Then, setting parameters are sent to the related device with “MATCH” button and the device becomes operational.

“IO TEST” buttons on the control panel interface can be used for testing the correct cable connection of the device. The state of the desired output can be changed as on/off and energy flow towards the terminal is identified.

8: Regulations

Legal Warning

The properties, functionalities and other product properties can be changed without prior notice. inohom reserves the right to review or update the products, software or documents without any liability to notify any individuals or organizations. Inohom is a trademark of GST Elektronik Elektrik Yazılım Makina Dan. San. ve Tic. Ltd. Şti. All other brand and product names herein are the trademarks of their respective owners.

Declaration of Conformity



The company has ISO 9001 Quality Management, 14001 Environment Management, 45001 Occupational Health and Safety Standards.



The domestic production logo on all the products show that the manufacturing and software are 100% completed in Turkey.



CE mark is a free trademark only for authorized officials and this mark does not contain any property assurance.



The product box is manufactured from a recyclable material. Do not discard the package waste with domestic or other waste and recycle package wastes.



The devices tagged with WEEE symbol shall not be discarded with other domestic waste. The product should be delivered to the related collection point for waste electric and electronic equipment recycle.

inohom

Smart Life Solutions

📍 GST Elektronik Elektrik Yazılım Makina Dan. San. Ve Tic. Ltd. Sti.

📍 Kemaloz Mah. Degirmendere Cad. No:8/A 64100 Usak/Turkey

🌐 www.inohom.com

☎ 0090 850 811 82 83

✉ info@inohom.com